

# PRODUCT INFORMATION PACKET

Model No: 405TTTS16537

Catalog No: U1879

100 HP Severe Duty Motor, 3 phase, 1800 RPM, 230/460 V, 405TV Frame, TEAO  
Low Voltage NEMA Cooling Tower Motors





**Nameplate Specifications**

Output HP	100 Hp	Output KW	75.0 kW
Frequency	60 Hz	Voltage	230/460 V
Current	226.0/113.0 A	Speed	1780 rpm
Service Factor	1.15	Phase	3
Efficiency	95.4 %	Power Factor	87
Duty	Continuous	Insulation Class	F
Design Code	B	KVA Code	F
Frame	405TV	Enclosure	Totally Enclosed Air Over
Thermal Protection	No	Ambient Temperature	40 °C
Drive End Bearing Size	6316	Opp Drive End Bearing Size	6313
UL	Recognized	CSA	Y
CE	N	IP Code	56

**Technical Specifications**

Electrical Type	Squirrel Cage Inverter Rated	Starting Method	Line Or Inverter
Poles	4	Rotation	Reversible
Resistance Main	.054 Ohms	Mounting	Rigid base
Motor Orientation	Horizontal Or Up Or Down	Drive End Bearing	Ball
Opp Drive End Bearing	Ball	Frame Material	Cast Iron
Shaft Type	T	Overall Length	34.31 in
Frame Length	16.75 in	Shaft Diameter	2.875 in
Shaft Extension	7.53 in	Assembly/Box Mounting	F1/F2 CAPABLE
Outline Drawing	B-SS516880-1675	Connection Drawing	A-EE7308K

This is an uncontrolled document once printed or downloaded and is subject to change without notice. Date Created:05/05/2020

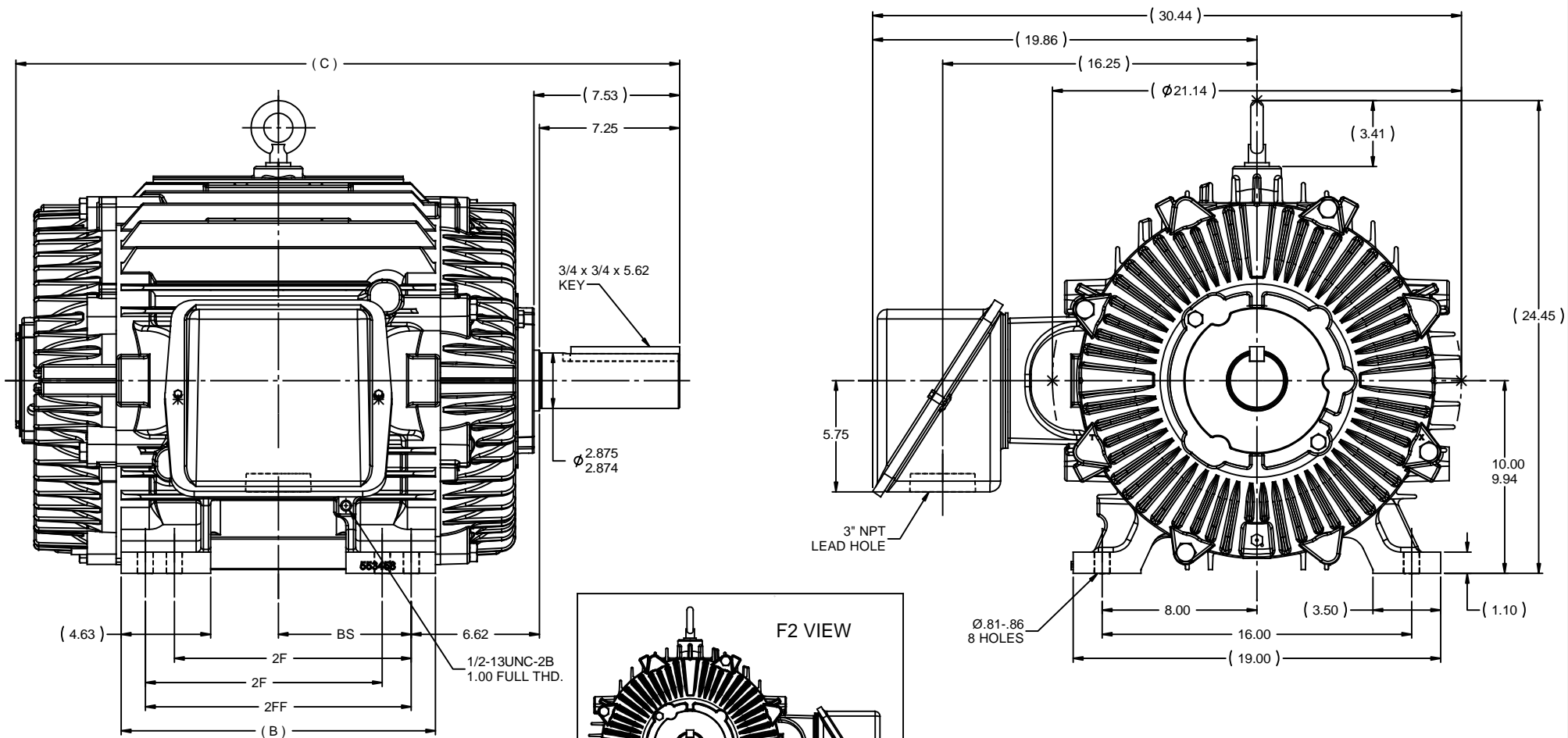

- NOTES:
1. CONDUIT BOX CAN BE ROTATED IN 90° STEPS.
  2. CONDUIT BOX CAN BE MOUNTED ON OPPOSITE SIDE BY REMOVING BRACKETS AND TURNING FRAME 180°.
  3. NAMEPLATES TO BE READ FROM CONDUIT BOX SIDE OF MOTOR.

DASH	FRAME	B	C	2F	2FF	BS
1675	404/405T	16.25	34.31	12.25	13.75	6.88

				TOLERANCES UNLESS SPECIFIED		marathon electric		DRAWN KL 12-01-1998		
				DEC	INCHES			CHK DJK 12-01-1998		
				x	±.1			APPR DJK 12-01-1998		
				xx	±.03	TITLE OUTLINE		SCALE 1:5		
2 UPDATED TO CURRENT FRAME STD'S. ISAAC 09-5049				JJB	6/13/2011	MH	xxx	±.005	400T FR. - TENV - TAPPED LEAD HOLE	
1 NEW DRAWING MU22869				KL	12/1/1998		xxxx	±.0005	REF	
				NO	REVISION	BY & DATE	CHK	ANG	±1/2°	FINISH
							RFP	12-01-1998	PREV	PAGE OF
							NETWORK FILE NAME	SS516880	SIZE	DRAWING NO
									B	SS516880
										REV
										2

LOW VOLTAGE



HIGH VOLTAGE



VIEW OF TERMINAL END

				TOLERANCES UNLESS SPECIFIED		REGAL REGAL-BELOIT CORPORATION		DRAWN PGK 06-04-1997					
NO.	REVISION	BY & DATE	CHK	ANG	±	INCHES	FINISH	SCALE	PREV				
E	CORRECTED IEC MARKINGS ECD-0111208	WGJ 01-23-2017	EMH	DEC.					CHK ML 06-05-1997				
D	RE-DRAWN WITH REGAL LOGO ECD-0110493	WGJ 09-30-2016	EMH	.X	±.1				APPD GK 06-15-1997				
8	ADDED IEC DESIGNATIONS MU95020	TJW 4/30/2010	MJS	.XX	±.02		TITLE CONNECTION DIAGRAM						
7	REVISED HIGH VOLTAGE L2 WAS L3 CN52600-354	MRB 09-21-1998		.XXX	±.005		TITLE DELTA CON. - 3Ø - 9 LEADS		REF				
6	REDRAWN ON CADD	PGK 06-05-1997		.XXXX	±.0005		MAT'L.		FMF				
					±7'30"								
THIS DRAWING IN DESIGN AND DETAIL IS OUR PROPERTY AND MUST NOT BE USED EXCEPT IN CONNECTION WITH OUR WORK ALL RIGHTS OF DESIGN AND INVENTION ARE RESERVED THIS IS AN ELECTRONICALLY GENERATED DOCUMENT - DO NOT SCALE THIS PRINT							RFP	CAD FILE EE7308K		SIZE A	DRAWING NO. EE7308K	PAGE OF	REV. E
							DIST						



Data Sheet

Date: 6/29/2017

4051TTS16537

Customer:



Submital

Attention:

FAREEDA DUDEKULA

Data @ 460 V

Submitted by:

Motor Load Data

Load	0%	25%	50%	75%	100%	115%	125%	LR
Current (Amps)	28.0	39.0	60.0	84.5	113	130	142	675
Torque (ft-lb)	0.00	73.0	147	221	295	341	370	445
RPM	1800	1795	1790	1785	1780	1,775	1770	0
Efficiency (%)		94.5	95.8	95.8	95.4	95.0	94.5	
P.F. (%)	4.5	64.0	81.5	86.0	87.0	87.5	87.5	28.0

Motor Speed Data

	LR	Pull-Up	BD	Rated	Idle
Speed (rpm)	0	900	1675	1780	1800
Current (Amps)	675	610	370	113	28.0
Torque (ft-lb)	445	400	715	295	0.00

Information Block

HP	100.0
Sync. RPM	1800
Frame	405
Enclosure	TEAO
Construction	TTS
Voltage	30/460#190/38 V
Frequency	60 Hz
Design	B
LR Code letter	F
Service Factor	1.15
Temp Rise @ FL	0 °C
Duty	CONT
Ambient	40 °C
Elevation	1,000 feet
Rotor/Shaft wkt	27.0 Lb-Fe
Rel Wdg	T405472 R18
Sound Pressure @ 1M	999 dBA
VFD Rating	CONSTANT 20.1
Outline Dwg	B-SS516880-1675
Conn. Diag	A-EE7308K
Additional Specifications:	
0	
EQUIV CKT (OHMS / PHASE)	
R1	R2
0.0430	0.0280
X1	X2
0.2980	0.2780
Xm	Xm
	9.2020

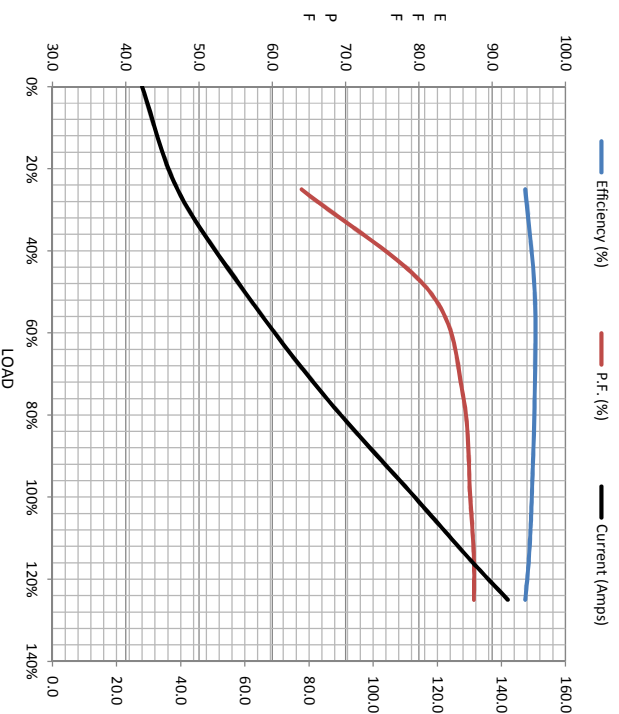

Speed - Torque Curve

